

DAN DRYER STAINLESS DESIGN



STAINLESS DESIGN

High-standard toilet equipment featuring exclusive, timeless design



EXCLUSIVE - TIMELESS - PROFESSIONAL





STAINLESS DESIGN

When quality and aesthetics go hand-in-hand

Stainless Design is a complete product line for toilets, in which quality and aesthetics are paramount. The entire range is made of strong quality materials, featuring unique design with a beautifully arched housing in brushed stainless steel.

The range has been developed by DAN DRYER and presents a wide range of hygiene solutions that can be combined as needed, to create a complete and individual solution without having to compromise on harmony and uniformity.

Toilet equipment in a given signature colour is also an option with Stainless Design. The products are available in all RAL colours or coated with different prints – facilitating styling and customising to any colour scheme or visual identity.

The concept of Stainless Design is to meet the need for a complete range of exclusive equipment focusing on efficiency, hygiene and durability. The products are designed specifically for use in public toilets where low-maintenance is called for, and equipment must be able to withstand the intense and rough treatment it is often subjected to.

This also explains the distinctive design of the range. The arched housing prevents dust and dirt from accumulating, whilst making it difficult to place undesired waste on the product. An extremely hygienic and cleaning-friendly solution. Not only is the design attractive, but the curved shape without edges or protruding joints serves as effective protection against vandalism. The strong materials are yet another advantageous feature that makes Stainless Design the obvious choice when equipping public toilets.

Why specify DAN DRYER STAINLESS DESIGN?

- **Complete and individual interior solution**
- **Can be matched with any style/colour scheme**
- **Specifically designed for public use**
- **Elegant and timeless design**
- **Professional advice and knowledge-sharing**



HYGIENIC

Easy maintenance of a clean environment. That is why all DAN DRYER products are designed with clean lines and no awkward inaccessible corners.



ECONOMIC

Durability and quality to avoid frequent reinvestment and reduce operating costs. Try out our savings calculator on www.dandryer.com and see how much you can save e.g. with a DAN DRYER hand dryer.



RELIABLE

Quality is the core of DAN DRYER and as a result we can offer exceptionally stable and durable equipment that is easy to maintain at all times.



ENVIRONMENT-FRIENDLY

Products from DAN DRYER produce virtually no waste other than the packaging they are delivered in. Functional solutions ensure optimal use of consumer products and low power consumption.



TIMELESS

DAN DRYER is known for its simple and timeless design able to fit into any environment with respect for architecture and interior design.



STAINLESS DESIGN

Stylish elegance for public toilets



No matter whether new build or refurbishment, Stainless Design is the ideal choice when selecting interior equipment for public toilets.

Stainless Design offers a range of high quality functional and user-friendly hygiene solutions in a unique combination of modern technology and elegant design.

Simple, timeless design makes these products highly flexible and usable in any environment – from modern cultural and educational institutions to historical, traditional museums.

Designed to complement any architecture and interior design style, Stainless Design meets the demand for individual solutions focusing on efficiency, hygiene and durability, combined with stylish elegance.

Typical locations for STAINLESS DESIGN:

- Airports
- Public buildings
- Educational institutions
- Shopping malls
- Museums
- Holiday resorts
- Hotels
- Restaurants
- Music and cultural centres
- Event and sports arenas



STAINLESS DESIGN

Product overview/contents

| Article No. | Product | Page | Page |
|-------------|--|------|------|
| 280 | Hand dryer AE Design | Page | 6 |
| 288 | Hand dryer Turbo Design | Page | 6 |
| 281 | Hand dryer Mini Design | Page | 7 |
| 282 | Touch-free soap dispenser | Page | 7 |
| 295 | Touch-free foam soap dispenser | Page | 8 |
| 296 | Manual soap dispenser | Page | 8 |
| 297 | Manual disinfectant dispenser | Page | 9 |
| 298 | Manual foam soap dispenser | Page | 9 |
| 284 | Waste bin | Page | 10 |
| 279 | Mini waste bin/sanitary bin | Page | 10 |
| 283 | Sanitary bin | Page | 11 |
| 277 | Toilet paper dispenser for 1 standard size roll | Page | 11 |
| 278 | Toilet paper dispenser for 2 standard size rolls | Page | 12 |
| 285 | Toilet paper dispenser for 4 standard size rolls | Page | 12 |
| 287 | Toilet paper dispenser for 1 JUMBO roll | Page | 13 |
| 289 | Toilet paper dispenser for 1 JUMBO roll + 1 standard size roll | Page | 13 |
| 286 | Paper towel dispenser | Page | 14 |
| 28000 | Stainless steel care | Page | 14 |

AE Design

A very sturdy and vandal-resistant all-round hand dryer for all types of public toilets.

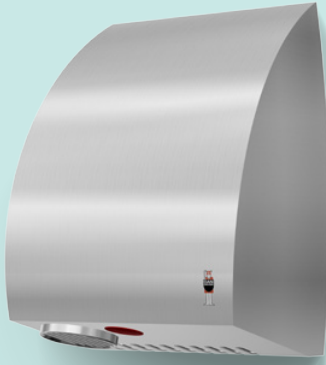

- Reliable, touch-free hand dryer with a soft and warm air flow to provide comfortable and effective hand drying.
- Drying cycle of approx. 20-25 seconds.
- Almost maintenance-free machine with induction motor.
- Adjustable sensor range.
- With lock for effective protection against vandalism.
- Comes in brushed and polished stainless steel as standard.
- Also available in all RAL colours and coated with different prints.
- 5-year warranty, even in cases of vandalism.

ARTICLE NO.: 280 - TECHNICAL DATA:

Touch-free hand dryer with housing in 1.5 mm brushed stainless steel. Infra-red sensor and electronic timer. Drying cycle: 20-25 sec. IP23, 230 V, 50/60 Hz, 2360 W, Class I (earthed), 62 dBA.

Net weight: 7.65 kg

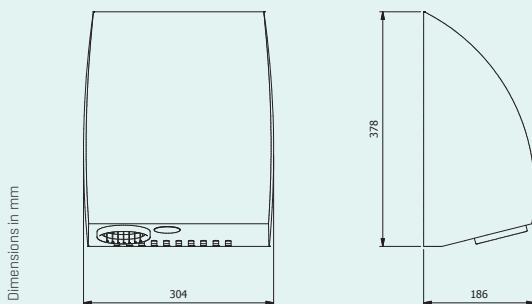

Turbo Design

Turbo is a powerful machine and therefore best suited for places with some tolerance of noise.

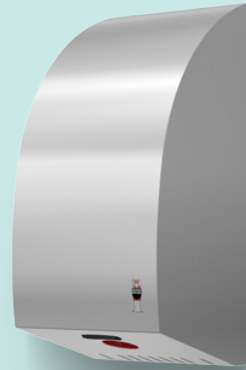

- Touch-free hand dryer with a powerful and warm air flow to provide fast and effective hand drying.
- Drying cycle of only 10-15 seconds.
- Equipped with a powerful commutator motor with carbon brushes.
- Adjustable sensor range, motor speed and heating element setting.
- With lock for effective protection against vandalism.
- Comes in brushed stainless steel as standard.
- Also available in all RAL colours and coated with different prints.
- 5-year warranty.

ARTICLE NO.: 288 - TECHNICAL DATA:

Touch-free hand dryer with housing in 1.5 mm brushed stainless steel. Infra-red sensor and electronic timer. Drying cycle: 10-15 sec. IPX1, 230 V, 50/60 Hz, 1600 W, Class I (earthed), 78 dBA.

Net weight: 6.9 kg

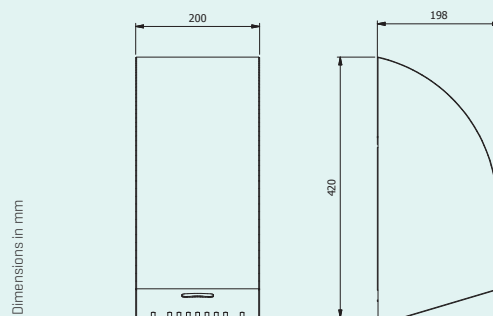

Mini Design

This hand dryer is less powerful than other DAN DRYER models and therefore ideal for toilets with relatively few users.

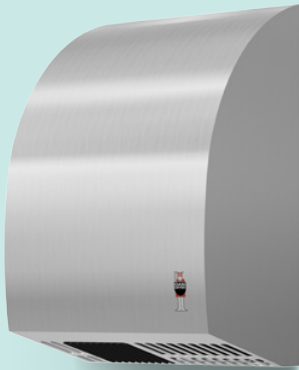

- Drying cycle of approx. 30 seconds.
- Almost maintenance-free machine with induction motor.
- Adjustable sensor range.
- With lock for effective protection against vandalism.
- Comes in brushed stainless steel as standard.
- Also available in all RAL colours and coated with different prints.
- 3-year warranty

ARTICLE NO.: 281 - TECHNICAL DATA:

Touch-free hand dryer with housing in 1.5 mm brushed stainless steel. Infra-red sensor and electronic timer. Drying cycle: approx. 30 sec. IP21, 230 V, 50/60 Hz, 1800 W, Class I (earthed), 64 dBA.

Net weight: 6 kg

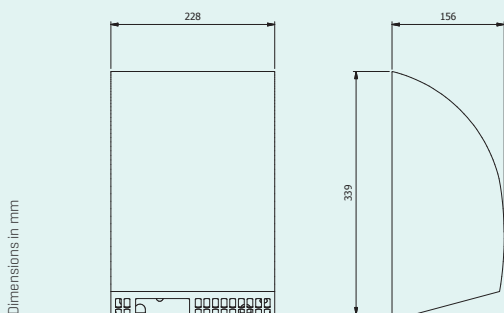

Dimensions in mm

Touch-free soap dispenser

Elegant and reliable soap dispenser ideal for all types of public toilets.

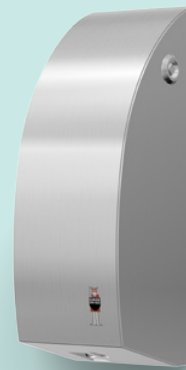

- Holds approx. 9.5 dl. liquid soap/disinfectant [= 800-950 doses].
- Battery-operated, runs on 4 x 1.5 V batteries.
- Can be connected to power supply via a transformer.
- An intelligent sensor automatically sets the best sensor range.
- LED light indicates when dispenser is in use.
- With lock for effective protection against vandalism.
- Comes in brushed stainless steel as standard.
- Also available in all RAL colours and coated with different prints.
- 2-year warranty.

ARTICLE NO.: 282 - TECHNICAL DATA:

Touch-free soap dispenser for liquid soap/disinfectant. Housing in 1.5 mm brushed stainless steel, AISI 304. Capacity: 9.5 dl. Battery-operated.

Net weight: 2.5 kg

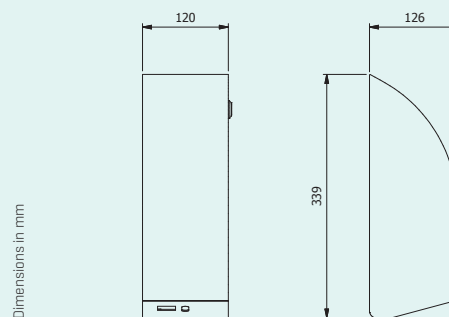

Dimensions in mm

Touch-free foam soap dispenser

Elegant and reliable foam soap dispenser ideal for all types of public toilets.

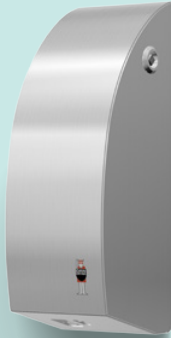

- Holds approx. 8 dl. foam soap [= 650-800 doses].
- Economic hygiene solution with minimum soap consumption per dose.
- Battery-operated, runs on 4 x 1.5 V batteries.
- Can be connected to power supply via a transformer.
- An intelligent sensor automatically sets the best sensor range.
- LED light indicates when dispenser is in use.
- With lock for effective protection against vandalism.
- Comes in brushed stainless steel as standard.
- Also available in all RAL colours and coated with different prints.
- 2-year warranty.

ARTICLE NO.: 295 - TECHNICAL DATA:

Touch-free soap dispenser for foam soap.
Housing in 1.5 mm brushed stainless steel, AISI 304.
Capacity: 8 dl. Battery-operated.

Net weight: 2.75 kg

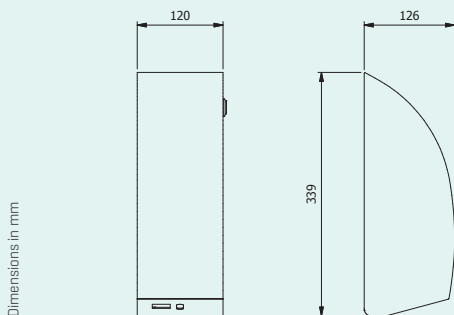

Manual soap dispenser

Elegant and reliable soap dispenser for liquid soap, suitable for all types of public toilets.

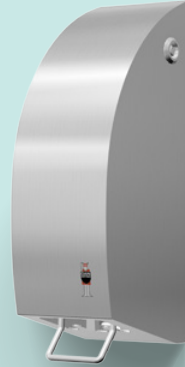

- Holds approx. 1.2 l. liquid soap [= 1000-1200 doses].
- With lock for effective protection against vandalism.
- Comes in brushed stainless steel as standard.
- Also available in all RAL colours and coated with different prints.
- 2-year warranty.

ARTICLE NO.: 296 - TECHNICAL DATA:

Manual dispenser for liquid soap.
Housing in 1.5 mm brushed stainless steel, AISI 304.
Capacity: 1.2 l.

Net weight: 2.75 kg

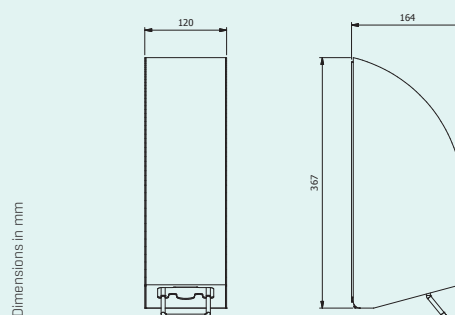

Manual disinfectant dispenser

Elegant and reliable dispenser for disinfectant, suitable for all types of public toilets.

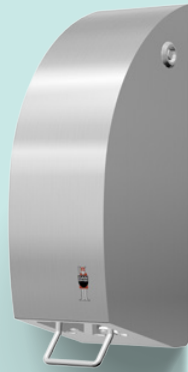

- Holds approx. 1.2 l. disinfectant (= 1000-1200 doses).
- With lock for effective protection against vandalism.
- Comes in brushed stainless steel as standard.
- Also available in all RAL colours and coated with different prints.
- 2-year warranty.

ARTICLE NO.: 297 - TECHNICAL DATA:

Manual dispenser for disinfectant.
Housing in 1.5 mm brushed stainless steel, AISI 304.
Capacity: 1.2 l.

Net weight: 2.75 kg

Dimensions in mm

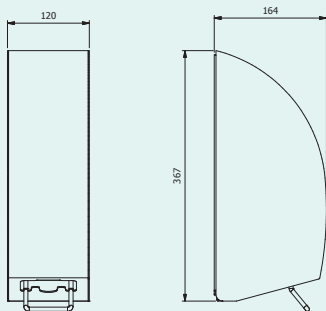

Manual foam soap dispenser

Elegant and reliable dispenser for foam soap, suitable for all types of public toilets.



- Holds approx. 1.2 l. foam soap (= 1000-1200 doses).
- Economic hygiene solution with minimum soap consumption per dose.
- With lock for effective protection against vandalism.
- Comes in brushed stainless steel as standard.
- Also available in all RAL colours and coated with different prints.
- 2-year warranty.

ARTICLE NO.: 298 - TECHNICAL DATA:

Manual dispenser for foam soap.
Housing in 1.5 mm brushed stainless steel, AISI 304.
Capacity: 1.2 l.

Net weight: 2.75 kg

Dimensions in mm

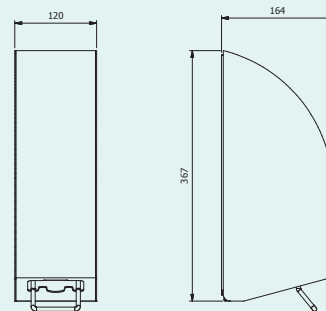

Waste bin

Large and easy-to-maintain waste bin. Extremely sturdy and ideal for all types of public toilets.



- Capacity: 30 l.
- Designed for wall mounting to facilitate floor washing and prevent theft.
- Featuring a hygienic and self-closing tip-down lid.
- Bags are easily fitted in the all-weld stainless steel inner bucket.
- Equipped with two gas springs for easy opening and closing of the bin front when emptying.
- With lock for effective protection against vandalism.
- Comes in brushed stainless steel as standard.
- Also available in all RAL colours and coated with different prints.
- 2-year warranty.

ARTICLE NO.: 284 - TECHNICAL DATA:

Waste bin in 1.5 mm brushed stainless steel, AISI 304. Capacity: 30 l. Equipped with self-closing tip-down lid, stainless steel inner bucket and gas springs.

Net weight: 17.2 kg

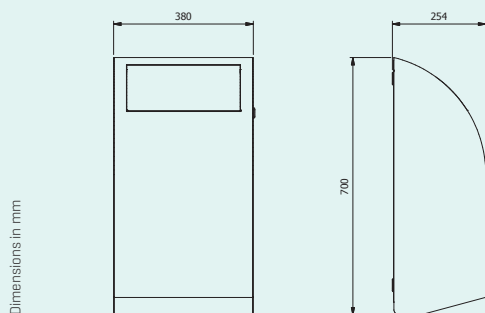

Mini waste bin/sanitary bin

Ideal hygienic solution for small toilets. Suitable as sanitary bin as well as small waste bin.



- Capacity: 11 l.
- Designed for wall mounting to facilitate floor washing and prevent theft.
- Featuring a flap lid, easily lifted to reveal a wide waste disposal opening.
- Bags are easily fitted in the all-weld stainless steel inner bucket.
- With lock for effective protection against vandalism.
- Comes in brushed stainless steel as standard.
- Also available in all RAL colours and coated with different prints.
- 2-year warranty.

ARTICLE NO.: 279 - TECHNICAL DATA:

Waste bin/sanitary bin in 1.5 mm brushed stainless steel, AISI 304. Capacity: 11 l. Equipped with flap lid and stainless steel inner bucket.

Net weight: 8.1 kg

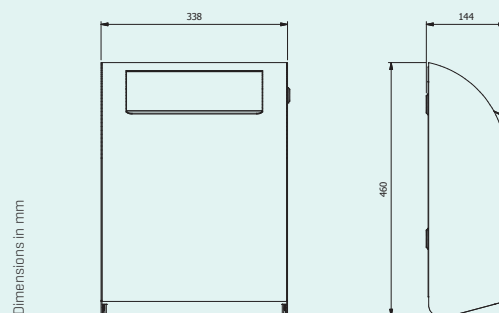

Sanitary bin

Elegant and sturdy sanitary bin, ideal for all types of public toilets.



- Capacity: 7 l.
- Designed for wall mounting to facilitate floor washing and prevent theft.
- Hygienic tip-up lid ensures that contents of the bin remain out of sight for the user at all times.
- Bags are easily fitted in the all-weld inner bucket.
- With lock for effective protection against vandalism.
- Comes in brushed stainless steel as standard.
- Also available in all RAL colours and coated with different prints.
- 2-year warranty.

ARTICLE NO.: 283 - TECHNICAL DATA:

Sanitary bin in 1.5 mm brushed stainless steel, AISI 304. Capacity: 7 l. Equipped with tip-up lid and stainless steel inner bucket.

Net weight: 7 kg

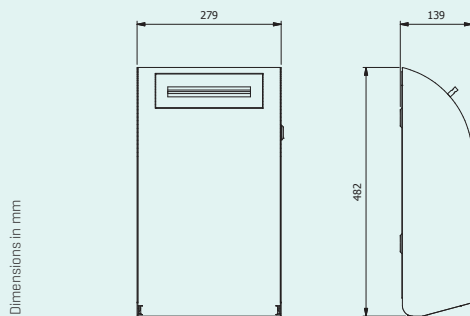

Toilet paper dispenser for 1 standard size roll

Ideal for all toilets for uncompromising quality and aesthetics, even in small rooms.



- Designed for wall mounting.
- Ideal for small rooms.
- Easy to open ensuring quick roll replacement.
- Comes in brushed stainless steel as standard.
- Also available in all RAL colours and coated with different prints.
- 2-year warranty.

ARTICLE NO.: 277 - TECHNICAL DATA:

Toilet paper dispenser in 1.5 mm brushed stainless steel, AISI 304. Capacity: 1 standard size paper roll.

Net weight: 1.85 kg

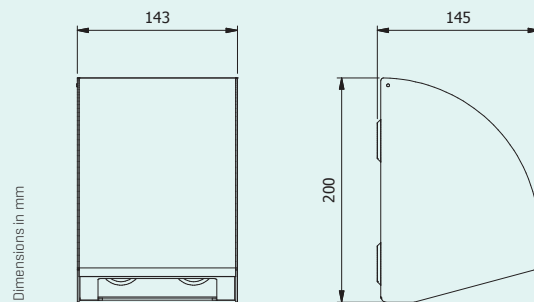

Toilet paper dispenser for 2 standard size rolls

Space-saving design for two standard size rolls side-by-side.



- Designed for wall mounting.
- Ideal for small rooms.
- Featuring a slide to screen the paper roll not in use.
- Comes in brushed stainless steel as standard.
- Also available in all RAL colours and coated with different prints.
- 2-year warranty.

ARTICLE NO.: 278 - TECHNICAL DATA:

Toilet paper dispenser in 1.5 mm brushed stainless steel, AISI 304. Capacity: 2 standard size paper rolls.

Net weight: 3 kg

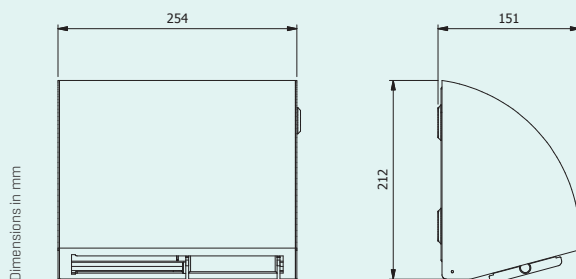

Toilet paper dispenser for 4 standard size rolls

Featuring an ingenious rotating plate to hold 4 standard rolls. When one roll is empty, the next one automatically falls into place.



- Designed for wall mounting.
- Ensures economical paper consumption, rolls that are still half full can be left in place when changing rolls.
- With lock for effective protection against vandalism.
- Comes in brushed stainless steel as standard.
- Also available in all RAL colours and coated with different prints.
- 2-year warranty.

ARTICLE NO.: 285 - TECHNICAL DATA:

Toilet paper dispenser in 1.5 mm brushed stainless steel, AISI 304. Capacity: 4 standard size paper rolls.

Net weight: 6.7 kg

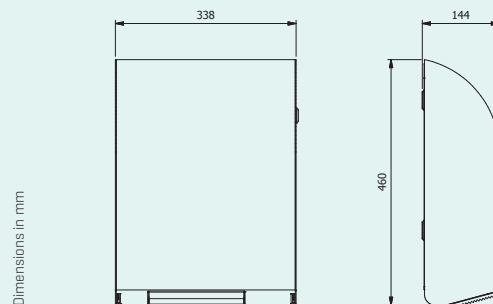

Toilet paper dispenser for 1 JUMBO roll

Functional and economical toilet roll holder for 1 JUMBO roll. Suitable for all types of public toilets.



- Designed for wall mounting.
- With lock for effective protection against vandalism.
- Comes in brushed stainless steel as standard.
- Also available in all RAL colours and coated with different prints.
- 2-year warranty.

ARTICLE NO.: 287 - TECHNICAL DATA:

Toilet paper dispenser in 1.5 mm brushed stainless steel, AISI 304. Capacity: 1 JUMBO size roll, max. 300 mm dia. [min. 55 mm dia. tube].

Net weight: 7.5 kg

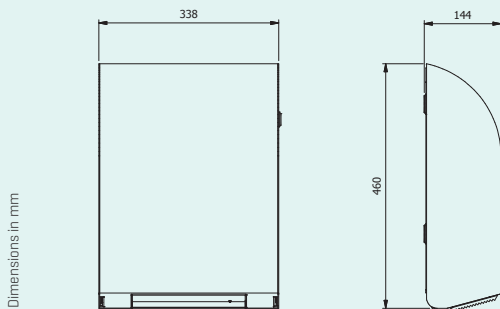

Toilet paper dispenser for 1 JUMBO roll + 1 standard size roll

The principle of combining a JUMBO roll with a standard roll in reserve ensures optimum paper consumption to save cost.



- Economic model with minimum waste of paper.
- When the JUMBO roll is empty, the small roll automatically falls into place.
- The front features a slot to check how much paper is left.
- With lock for effective protection against vandalism.
- Comes in brushed stainless steel as standard.
- Also available in all RAL colours and coated with different prints.
- 2-year warranty.

ARTICLE NO.: 289 - TECHNICAL DATA:

Toilet paper dispenser in 1.5 mm brushed stainless steel, AISI 304. Capacity: 1 JUMBO size roll + 1 standard size roll. JUMBO roll max. 285 mm dia. [min. 50 mm dia. tube].

Net weight: 9.9 kg

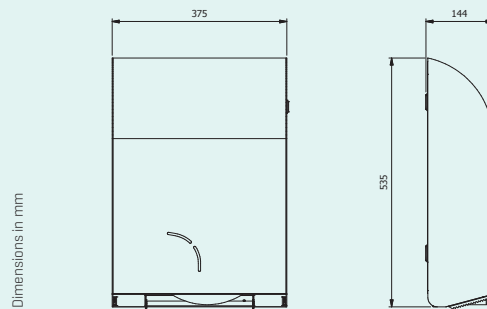

Paper towel dispenser

Holds 400 paper towels to reduce the need for service and refilling.



- Large capacity = less frequent service and refilling.
- Safe towel shear fitted to facilitate individual pull-out.
- With lock for effective protection against vandalism.
- Comes in brushed stainless steel as standard.
- Also available in all RAL colours and coated with different prints.
- 2-year warranty.

ARTICLE NO.: 286 - TECHNICAL DATA:

Paper towel dispenser in 1.5 mm brushed stainless steel, AISI 304. Capacity: Approx. 400 2-ply, Z/C-fold paper towels [max. 95 x 250 mm].

Net weight: 5 kg

Dimensions in mm

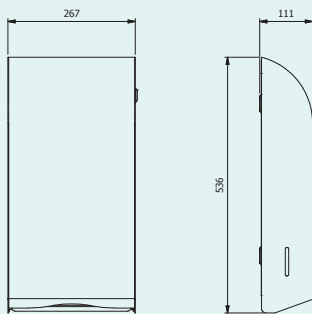

Stainless steel care

Efficient care spray for Stainless Design products. Ideal for products made of stainless steel, chrome and aluminium.



- Provides a shiny surface and protects against dirt and fingerprints.

ARTICLE NO.: 28000 - TECHNICAL DATA:

Holds 500 ml.

Net weight: 0.5 kg

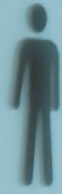

DAN DRYER



More than 30 years' experience within equipment for public toilets



Supplier – Advisory Service – Product Development

DAN DRYER was one of the very first hand dryer manufacturers on the market, and has gone on to establish a leading position as supplier of toilet equipment. The Viking logo is easily recognisable in public toilets all over the world. Many years' experience has led to the company becoming specialists within development and production of toilet equipment. We now offer our customers a wide range of products, right from hand dryers to complete hygiene solutions.

DAN DRYER is a solution-oriented company, developing products according to market needs, an approach that results in close dialogue-based cooperation with our customers, as we do not consider ourselves merely a supplier. We are also the ideal consultant and partner for discussion - always prepared to do more for our customers and to join product development projects.

With this approach, DAN DRYER has positioned itself internationally as one of the most preferred suppliers of toilet equipment, e.g. to airports, public institutions and retail chains, and we have earned a unique position as a niche manufacturer of technically complex and customised products to the rail industry.

Our strength lies in unique know-how and a company structure that enables us to respond quickly and flexibly to individual requirements and specifications. Whatever part of the process - from project stage to the finished building - we can always help find the right hygiene solution.

DAN DRYER A/S

Alsikevej 8 · DK 8920 Randers NV

Tel: +45 86 41 57 11 · Fax: +45 86 41 60 89 · dandryer@dandryer.dk

dandryer.com

